



Reduce disruptive EMI and RFI with Woodhead® MAX-LOC® Plus Shielded Cord-Grip Assemblies, featuring a simplified installation design ideal for high-frequency switched-mode power supply (SMPS) applications

Woodhead® MAX-LOC® Plus Shielded Cord-Grip Assemblies allow OEM's and end-user's to connect high-power electrical cables directly to an application via an exterior mounting enclosure, simplifying the installation process for high-volume, cost-sensitive programs. The robust assemblies provide excellent EMI and RFI shielding plus sealing protection (liquids and dust). MAX-LOC® Plus Shielded Cord-Grip Assemblies bring multiple features found across numerous products into a single-product solution. This unique design results in cost and labor savings over conventional industry-standard products.

Features

Benefits

Nickel-plated aluminum housing and shielding ring	Provide electro magnetic interference (EM) and radio frequency interference (RFI) protection
Unique grip-body internal cut-away design	Ensures a clear pass-through of pre-assembled harnesses and pre-crimped lugs through center and offset lugs. Provides simple assembly and field serviceability
Tapered shielding ring (as opposed to competitor's finger contacts)	Provides a robust, reliable connection. Ensures low contact resistance and cable grounding
Internal wedge-shaped grommet	Provides liquid and dust sealing and cable retention to withstand 50 pounds (222.4N) pull force versus two installers) directly to the OEM panel, enclosure or vehicle body. Ensures stable connection in rugged applications
Two external mounting holes	Simplify the installation process via a single-side connection (single person)
Aluminum die-cast, nickel-plated threaded assembly	Strong, light-weight design for ease of use. Reduces galling (wear and transfer of material between the assembly and panel)
Compression nut	Provides cable retention to withstand 222.4N (50 lbs.) pull force
Sealed O-ring, IP67 and IP69K rated	Seals out moisture and dust contamination. Meets SAE industry standards
Grip assembly accommodates 1 AWG, 1/0, 2/0 shielded cables with an expanded range to follow	Provides design flexibility and installed cost savings. Meets harsh-environment application requirements

**Woodhead®
MAX-LOC® Plus
Shielded Cord-Grip
Assemblies**

130199 MAX-LOC®
Plus Cord-Grip
Assemblies



MAX-LOC® Plus Shielded Cord-Grip Assembly with terminated VersaKrimp™ Compression Lug



Woodhead® MAX-LOC® Plus Shielded Cord-Grip Assemblies

Additional Product Features

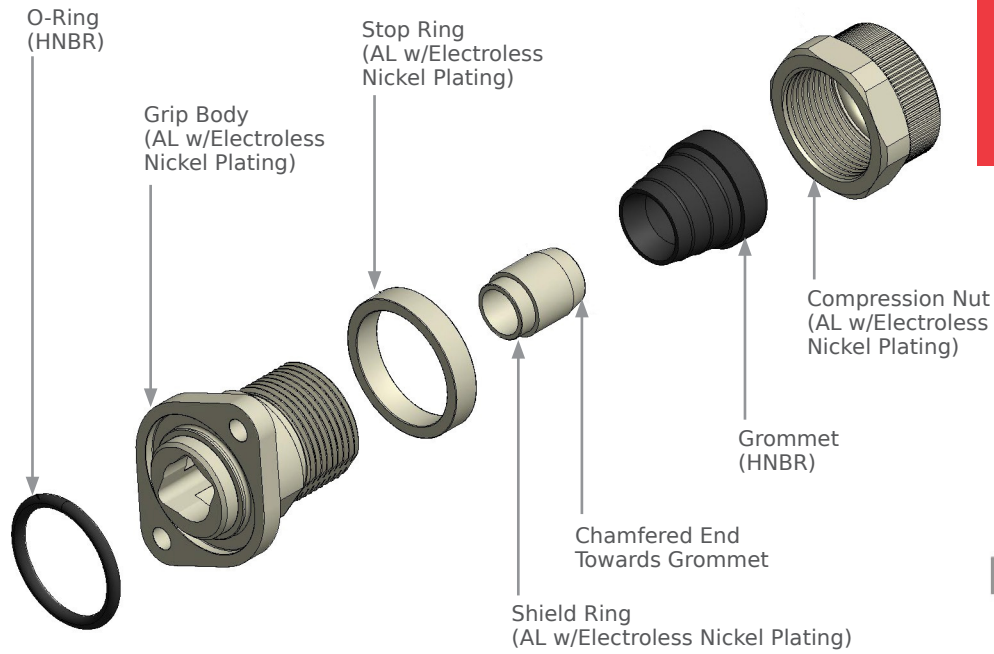

Exploded View of MAX-LOC® Plus Shielded Cord-Grip Assembly

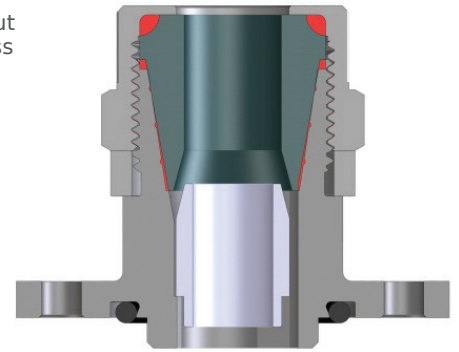

Cross View of MAX-LOC® Shielded Cord Grip Assembly

Applications

- Industrial (Automation)
 - Power-inverter, motor, drive installations
 - Factory automation
 - Process control
- Aerospace and Defense
 - Hybrid electric vehicles
 - Electrical-vehicle-drive systems
- Commercial Vehicle
 - Hybrid electric vehicles
 - Construction/agricultural
 - Buses
 - Mining
- Alternative Energy
 - Wind mills
 - Solar
 - Scientific
 - Bio-reactors
- Telecommunications/Networking
 - HVAC variable-speed motors

Component Assembly View with Shielded Cable

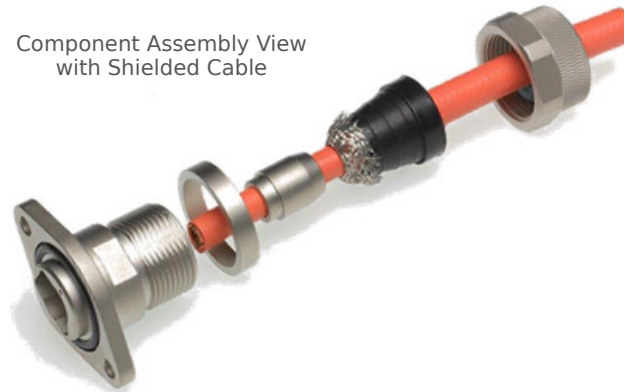

Pressure Washer



Specifications

REFERENCE INFORMATION

Packaging: Box
RoHS: Yes
Halogen Free: Yes

MECHANICAL:

Cable Retention:
50 pounds (222.4N) cable pull
withstand for 30 seconds

ELECTRICAL:

EMI/RFI Shielding: 360°
Die-Electric Withstand: 2400V AC for
1 minute

ENVIRONMENTAL:

Immersion: IP67 and IP68 rated
Power Wash (Duration of 5 Minutes):
12,000kPaG (~1740psig), 13 l/min
(~ 3.4 gal/min).
Operating Temperature:
HNBR — -40 to +150°C
Silicone — -60 to +200°C
UV resistant
Meets UL 94 VO flammability rating

PHYSICAL

Housing: Electroless nickel-plated
aluminum die-cast
Nut: Electroless nickel-plated
aluminum die-cast
Shield Ring: Electroless nickel-plated
aluminum die-cast
Stop Ring: Electroless nickel-plated
aluminum die-cast
Grommet: HNBR or Silicone
O-Ring: Nitrile or Silicone

Woodhead® MAX-LOC® Plus Shielded Cord-Grip Assemblies

Ordering Information

Order No.	Cable Gauge (AWG)
130199-0030	1
130199-0020	1/0
130199-0025	2/0
130199-0080	3/0

www.molex.com/product/maxlocplus.html