

Current Sensing Chip Resistors

Type SL/TSL Resistor

ISO 9001:2008
CERTIFIED
TS-16949
CERTIFIED

1. General

- Surface mount type
- Flameproof UL94V0 molded polymer case
- Excellent dimension accuracy, mountability and shock resistance
- Low profile type available (TSL)
- Products with lead-free terminations meet EU RoHS requirements. EU RoHS regulation is not intended for Pb-glass contained in electrode, resistor element and glass.
- AEC-Q200 Qualified

2. Type Designation

The type designation shall be in the following form:

New Type

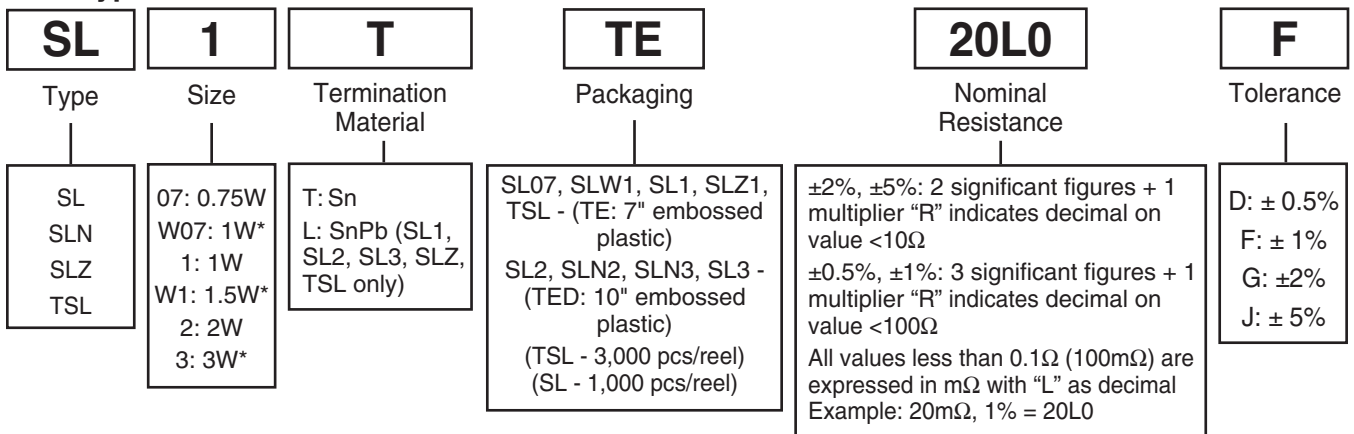

* Please ask us separately about Ratings and Performance

3. Standard Applications

Part Designation	Power Rating	T.C.R. (ppm/°C) Max.***	Resistance Range	Resistance Tolerance E-24*	Absolute Maximum Working Voltage	Absolute Maximum Overload Voltage	Operating Temperature Range
SL07	0.75W	0~200: R=<10mΩ 0~150: R=>11mΩ	5mΩ - 100mΩ	(F: ±1%) (J: ±5%)	—	—	-55°C to +180°C
NEW SLW07	1W	0~200: R=<10mΩ 0~150: R=>11mΩ	5mΩ - 100mΩ	(F: ±1%) (J: ±5%)	—	—	
SL1	1W	±180: R=<13mΩ ±100: R=>15mΩ	10mΩ - 1MΩ	(D: ±0.5%)	200V	400V	
			5mΩ - 1MΩ	(F: ±1%)			
			3mΩ, 4mΩ	(G: ±2%)			
			3mΩ ~ 22MΩ	(J: ±5%)			
NEW SLW1	1.5W	±180: R=<13mΩ ±100: R=>15mΩ	10mΩ - 100mΩ	(D: ±0.5%)	—	—	
			5mΩ - 100mΩ	(F: ±1%)			
			3mΩ, 4mΩ	(G: ±2%)			
			3mΩ ~ 100mΩ	(J: ±5%)			
SL2	2W	±180: R=<10mΩ ±100: R=>11mΩ	5mΩ - 200mΩ	(D: ±0.5%)	500V	1000V	
			5mΩ ~ 1MΩ	(F: ±1%)			
			3mΩ - 22MΩ	(J: ±5%)			
SLN2	2W	±110: R<10mΩ ±75: R=>10mΩ	5mΩ - 200mΩ	(D: ±0.5%) (F: ±1%) (G: ±2%) (J: ±5%)	—	—	
NEW SLN3	3W	±110: R<10mΩ ±75: R=>10mΩ	5mΩ - 110mΩ	(D: ±0.5%) (F: ±1%) (G: ±2%) (J: ±5%)	—	—	
SL3	3W	±180: R=<10mΩ ±100: R=>11mΩ	10mΩ - 100mΩ	(D: ±0.5%)	—	—	
			5mΩ - 100mΩ	(F: ±1%)			
			3mΩ - 100mΩ	(J: ±5%)			
SLZ1**	—	4000 Max.	0.5mΩ Max.	—	—	—	
TSL1	1W	±180: R=<13mΩ ±100: R=>15mΩ	10mΩ - 100mΩ	(D: ±0.5%)	—	—	
			5mΩ - 100mΩ	(F: ±1%)			
			5mΩ - 100mΩ	(J: ±5%)			

* 3m, 4m, 5m, 6m, 7m, 8m, 9m also available inside resistance range

** SLZ1: Current rating: 44A

*** Please contact factory for T.C.R.: ±50ppm/°C and ±75ppm/°C

4. Dimensions and Structure

4-1 Dimensions

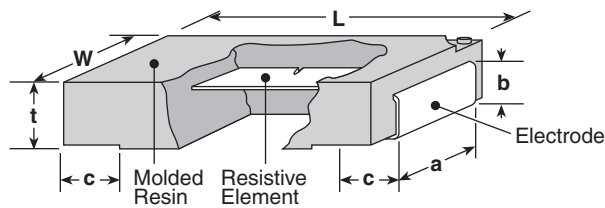

4-2 Structure

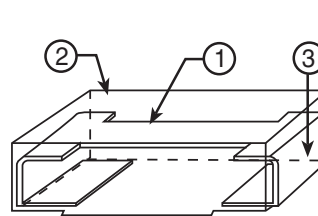

- ① Resistive Element
Metal Plate: SL1 ≤ 100 mΩ, SL2 ≤ 360 mΩ, SL3
Thick Film: SL1 > 100 mΩ, SL2 > 360 mΩ
- ② Flameproof Molded Epoxy Case with UL94V-0 Flammability Rating
- ③ End Termination with Tin/Lead Solder Plating

Size Code	Dimensions inches (mm)					
	L	W	t	a	b	c
SL07/SLW07 (2010)	.197±.012 (5.0±0.3)	.098±.008 (2.5±0.2)	.067±.008 (1.7±0.2)	.079±.008 (2.0±0.2)	.047±.008 (0.9±0.2)	.035±.012 (1.2±0.3)
SL1/SLW1, SLZ1 (2512)	.248±.012 (6.3±0.3)	.122±.008 (3.1±0.2)	.075±.008 (1.9±0.2)	.094±.008 (2.4±0.2)	.047±.008 (1.2±0.2)	.047±.012 (1.2±0.3)
SL2/SL3 (4528)	.453±.012 (11.5±0.3)	.276±.008 (7.0±0.2)	.098±.008 (2.5±0.2)	.197±.008 (5.0±0.2)	.067±.008 (1.7±0.2)	.102±.02 (2.6±0.5)
SLN2/SLN3 (4528)	.453±.012 (11.5±0.3)	.276±.008 (7.0±0.2)	.094±.008 (2.4±0.2)	.217±.008 (5.5±0.2)	.063±.008 (1.6±0.2)	.100±.016 (2.55±0.4)
TSL1 (2512)	.248±.012 (6.3±0.3)	.122±.008 (3.1±0.2)	.039±.008 (1.0±0.2)	.094±.008 (2.4±0.2)	.028±.008 (0.7±0.2)	.047±.012 (1.2±0.3)

5. Rating

Derating Curve

(SL07, SL1, SL2, SLN2, TSL1)

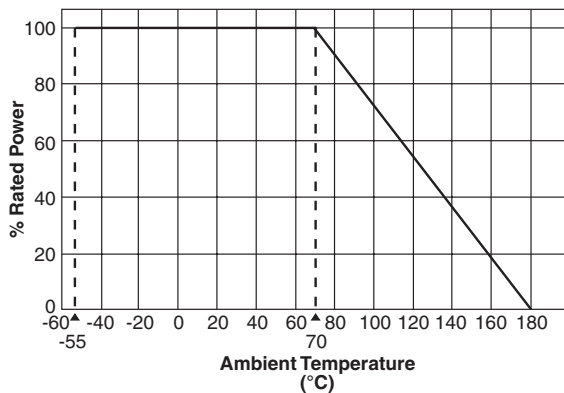

For resistors operated at an ambient temperature of 70°C or above, a power rating shall be derated in accordance with the above derating curve.
(Please ask separately us about Derating Curve for SLW07, SLW1, SL3, SLN3, SLZ1).

Surface Temperature Rise

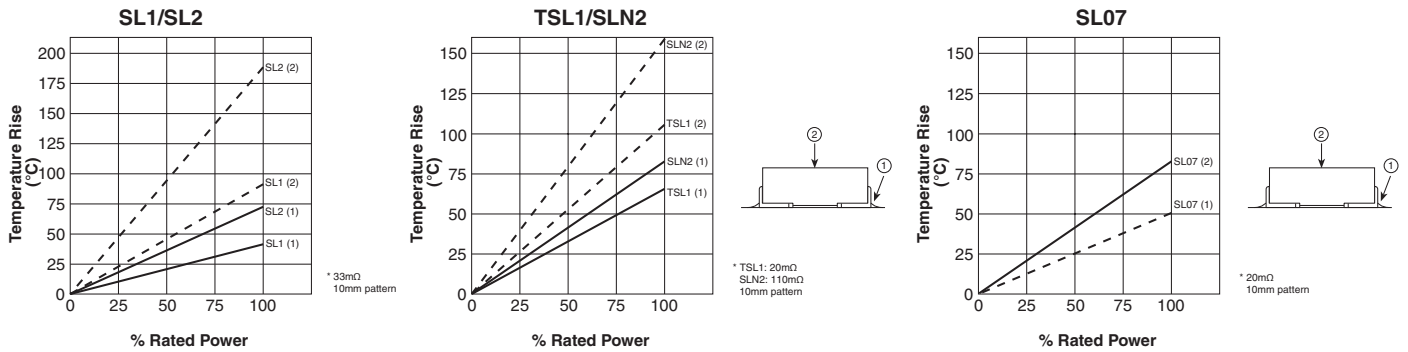

Regarding the temperature rise, the value of the temperature varies per conditions and board for use since the temperature is measured under our measuring conditions.

5-1 Rating SL3

For temperature in excess of 110°C, the load shall be derated in accordance with the following figure.

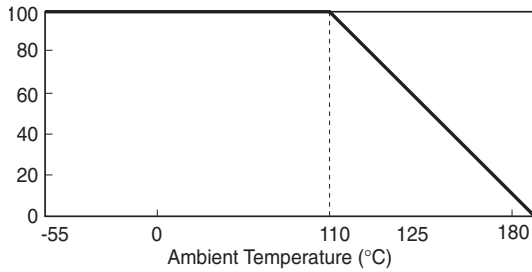

5-2 Voltage Rating

Resistors shall have a rated direct-current (DC) continuous working voltage or approximate sine-wave root-mean-square (RMS) alternating-current (AC) continuous working voltage at commercial-line frequency and waveform corresponding to the power rating, as determined from the following formula:

$$E = \sqrt{P \times R}$$

Where:
 E = Rated voltage (V)
 P = Rated power (W)
 R = Nominal resistance (Ω)

6. Characteristics

6-1 High Frequency Characteristics

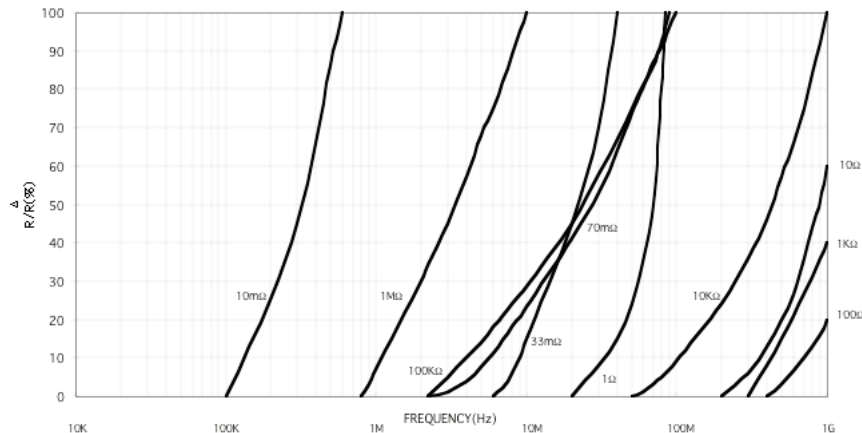

6-2 Performance Characteristics

Parameter	Requirement $\Delta R \pm\%$		Test Method
	Limit	Typical	
Resistance	Within specified tolerance	—	25°C
T.C.R.	Within specified T.C.R.	—	+25°C/+125°C
Overload (Short time)	SL07, TSL1,SL1, SL2: $\pm 1\%$ SLN2: $\pm 0.5\%$	SL07, TSL1,SL1, SL2: $\pm 1\%$ SLN2: $\pm 0.25\%$	SL07: Rated power x 4 for 5 seconds, TSL1: Rated power x 2.5 for 5 seconds, SL1, SL2, SLN2: Rated power x 5 for 5 seconds,
Resistance to Solder Heat	SL07, TSL1,SL1, SL2: $\pm 1\%$	SL07, TSL1,SL1, SL2: $\pm 1\%$	260°C $\pm 5^\circ\text{C}$, 10 ± 1 second
	SLN2: $\pm 0.5\%$	SLN2: $\pm 0.5\%$	260°C $\pm 5^\circ\text{C}$, 10~12 seconds
Rapid Change of Temperature	SL07, TSL1,SL1, SL2: $\pm 1\%$	SL07, TSL1,SL1, SL2: $\pm 0.5\%$	-55°C (30 minutes), +150°C (30 minutes), 100 cycles
	SLN2: $\pm 0.5\%$	SLN2: $\pm 0.25\%$	-55°C (15 minutes), +150°C (15 minutes), 1000 cycles
Moisture Resistance	SL07, TSL1,SL1, SL2: $\pm 2\%$	SL07, TSL1,SL1, SL2: $\pm 0.5\%$	40°C $\pm 2^\circ\text{C}$, 90%~95%RH, 1000 hours, 1.5 hr ON, 0.5 hr OFF cycle
	SLN2: $\pm 0.5\%$	SLN2: $\pm 0.25\%$	85°C $\pm 2^\circ\text{C}$, 85% $\pm 3\%$ RH, 1000 hours, Rated power x 0.1
Endurance at 70°C	SL07, TSL1,SL1, SL2: $\pm 2\%$ SLN2: $\pm 1\%$	$\pm 0.5\%$	70°C $\pm 2^\circ\text{C}$, 1000 hours, 1.5 hr ON, 0.5 hr OFF cycle
Low Temperature Exposure	$\pm 0.5\%$	$\pm 0.25\%$	SL07, TSL1, SL1, SL2: -55°C, 1 hour; SLN2: -65°C, 24 hours

7. Taping

7-1 Dimensions of Carrier Tape

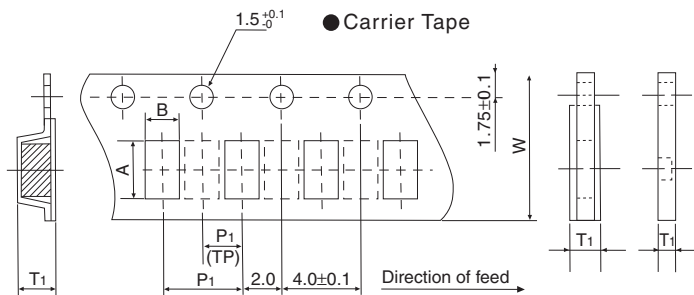

Type	Component Size (mm)				Carrier Tape	Quantity/ Reel (Pieces)	Taping (mm)					Reel Size
	L	W	T				A	B	W	P1	T1	
SL SLW	0.7	5.0	0.5	1.7	TE	2000	5.5 ± 0.1	3.1 ± 0.1	12	4	2.25 ± 0.10	180
	1	6.3	3.1	1.9	TE	1000	6.8 ± 0.1	3.6 ± 0.1	12.0 ± 0.1	8.0 ± 0.2	2.35 ± 0.1	180
	2/3	11.5	7	2.5	TED	1000	12.2 ± 0.1	7.7 ± 0.1	24	12.0 ± 0.1	3.1 ± 0.1	255
SLN	2/3	11.5	7	2.5	TED	1000	12.2 ± 0.1	7.7 ± 0.1	24	12 ± 0.2	3.1 ± 0.1	225
TSL	1	6.3	3.1	1	TE	3000	3.4 ± 0.1	6.6 ± 0.1	12.0 ± 0.1	4.0 ± 0.1	1.3 ± 0.1	180

7-2 Taped Configuration

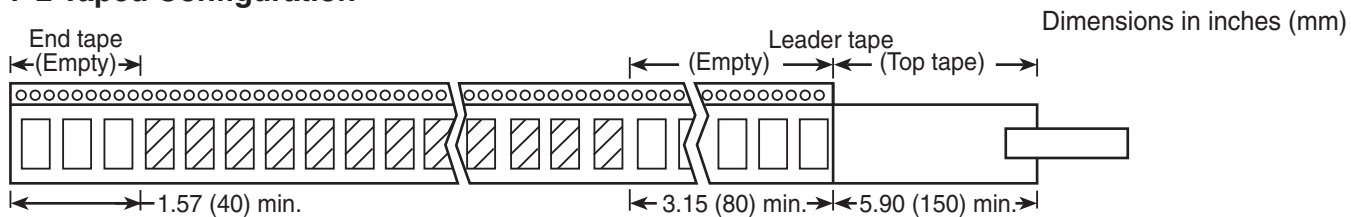

7-3 Reel Dimensions

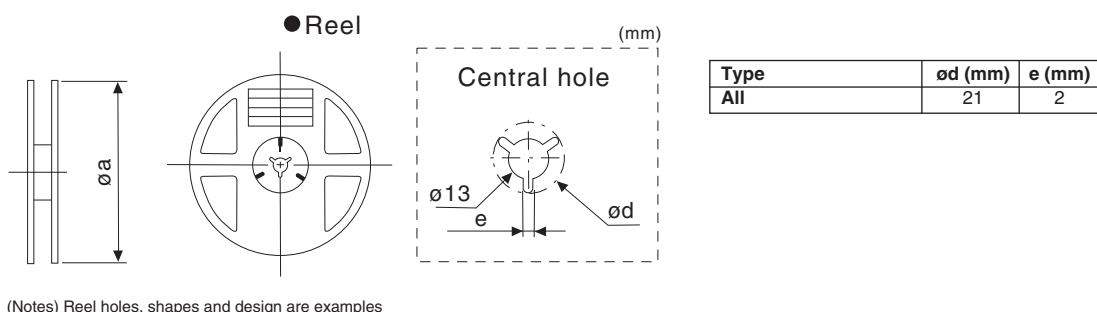

8. Recommended Land Pattern TSL1, SL1 & SL2

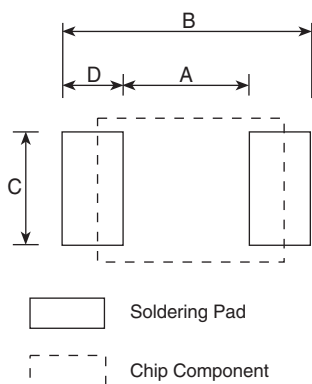

Type	Style	Dimensions millimeters				
		Component Size	A	B	C	D
SL/TSL	07	5.0 X 2.5	2.3	7.0	2.6	2.35
	1	6.3 X 3.1	3.4	8.0	3.0	2.3
	2-3	11.5 X 7.0	5.4	15.0	5.0	4.8
SLN	2/3	11.5 X 7.0	5.0	15.0	6.0	5.0

8-1 Body and Marking

Body color	Black
Marking color	White
Marking items	Resistance value and tolerance