

# DATA SHEET

## SHUNT RESISTOR

PU series

5%, 1%

sizes

3921/ 5931

RoHS compliant & Halogen free



**SCOPE**

This specification describes shunt resistor PU series with lead-free terminations made by welding technology.

**APPLICATIONS**

- Power
- Telecom base station
- Automotive (Headlight/ Window control/ Engine control unit/ Steering control...)
- Alternative energy

**FEATURES**

- AEC-Q200 qualified
- Resistance value down to 0.0002Ω and high power up to 10W
- Welding metal plate construction

**ORDERING INFORMATION - GLOBAL PART NUMBER**

Global part numbers are identified by the series, size, tolerance, packing type, temperature coefficient, taping reel and resistance value.

**GLOBAL PART NUMBER**

**PU XXXX X X X XX XXXX L**  
 (1) (2) (3) (4) (5) (6) (7)

**(1) SIZE**

3921/ 5931

**(2) TOLERANCE**

F = ±1% J = ±5%

**(3) PACKAGING TYPE**

K = Embossed taping reel

**(4) TEMPERATURE COEFFICIENT OF RESISTANCE**

M = ±75 ppm/°C

N = ±175 ppm/°C

H = ±225 ppm/°C

O = ±325 ppm/°C

**(5) TAPING REEL**

I3 = 13 inch Dia. reel, standard power, 3W for 3921 and 5W for 5931

P5 = 5W , 13 inch Dia. reel, 3921 only

P7 = 7W, 13 inch Dia. reel

P9 = 9W , 13 inch Dia. reel

T3 = 3W , High temperature 13 inch Dia. reel

T5 = 5W , High temperature 13 inch Dia. reel

PA = 10W, 13 inch Dia. reel

**(6) RESISTANCE VALUE**

0.2 mΩ to 4 mΩ

There are 3~5 digits indicated the resistance value. Letter R/ U is decimal point.

Detailed coding rules of resistance are shown in the table of "Resistance rule of global part number".

**(7) DEFAULT CODE**

Letter L is the system default code for ordering only. (Note)

Resistance code rule	Example
0RXXX	0R001 = 1 mΩ
0UX	0U2 = 0.0002 Ω

**ORDERING EXAMPLE**

The ordering code of a PU3921, value 0.0005Ω with ±1% tolerance, 3W and high temperature(275°C) supplied in 13-inch tape reel is :  
**PU3921FKNT30U5L**

**NOTE**

I. All our RSMD products are RoHS compliant. "LFP" of the internal 2D reel label mentions "Lead-Free Process"

**MARKING**

0.2mΩ , 0.3mΩ , 0.5mΩ

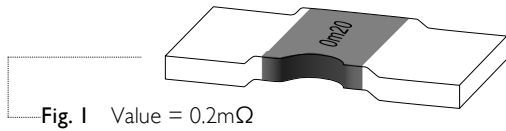

**4 digits**

The "m" is used as a decimal point ; the other 3 digits are significant and the unit is milliohm

0.2mΩ to 0.5mΩ

1~4mΩ

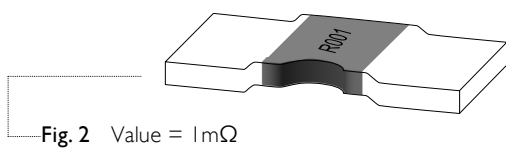

**4 digits**

The "R" is used as a decimal point ; the other 3 digits are significant

1mΩ to 4mΩ

**OUTLINES AND DIMENSION**

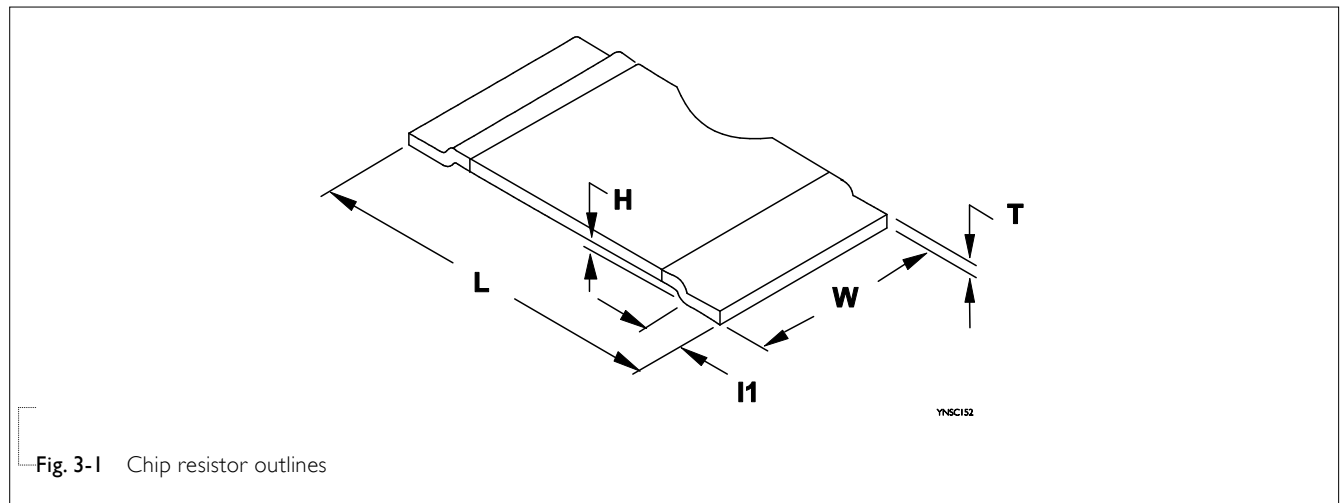

Table I-1 For outlines, please refer to Fig. 3-1

TYPE	L (mm)	W (mm)	H (mm)	I1 (mm)
PU3921	10.0±0.25	5.20±0.25	0.50±0.13	2.00±0.25
PU5931	15.0±0.25	7.75±0.25	0.50±0.13	4.00±0.25

Resistance Value	0.2mΩ	0.3 mΩ	0.5 mΩ	1 mΩ	2 mΩ	3 mΩ	4 mΩ
T (mm)	PU3921 1.35±0.13	1.35±0.13	0.86±0.13	0.43±0.13	0.72±0.13	0.48±0.13	0.36±0.13
Thickness	PU5931 1.33±0.13	1.00±0.13	0.60±0.13	0.33±0.13	0.49±0.13	0.33±0.13	0.25±0.13

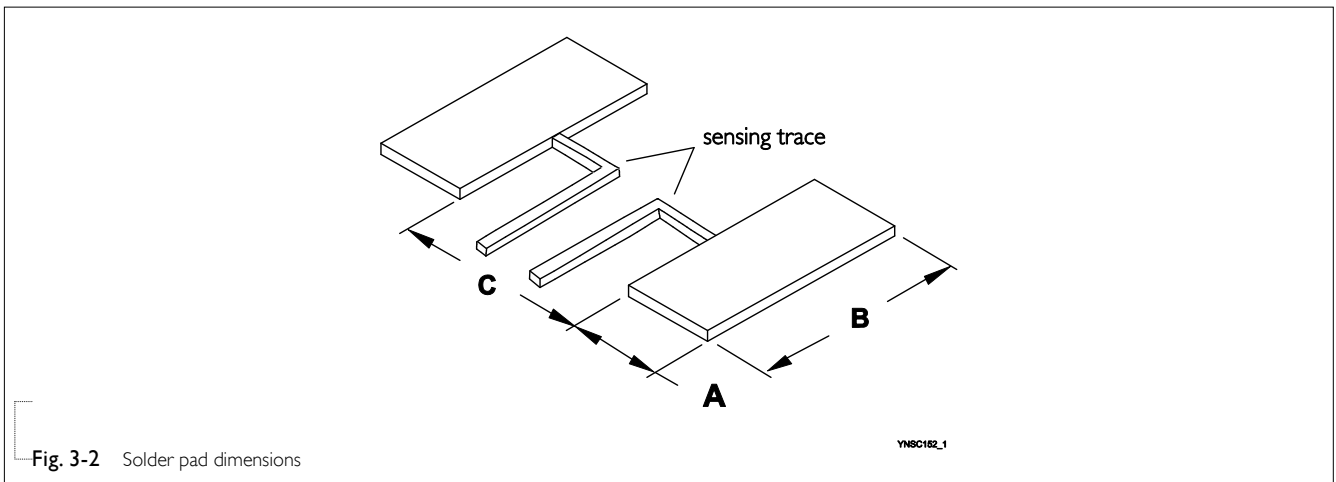

Fig. 3-2 Solder pad dimensions

Note: Series resistors are suitable for IR reflow soldering

Table I-2 For outlines, please refer to Fig. 3-2

TYPE	A (mm)	B (mm)	C (mm)
PU3921	2.75±0.25	6.20±0.25	5.60±0.13
PU5931	5.20±0.25	8.75±0.25	5.60±0.13

Table 2

**ELECTRICAL CHARACTERISTICS**

SIZE	POWER RATING	OPERATING TEMP. RANGE	RESISTANCE RANGE	TOLERANCE	TEMPERATURE COEFFICIENT OF RESISTANCE
PU3921	3W	-65°C to 170°C	0.2mΩ/ 0.3mΩ/ 0.4mΩ/ 0.5mΩ 1 mΩ/ 2mΩ/ 3mΩ/ 4mΩ	±1%,±5%	0.2mΩ/ 0.3mΩ/ 0.4mΩ/ 0.5mΩ: ±175ppm/°C 1mΩ~4mΩ: ±75ppm/°C
	5W		0.2mΩ/ 0.3mΩ/ 0.4mΩ/ 0.5mΩ 1mΩ/ 2mΩ/ 3mΩ/ 4mΩ		0.2mΩ: ±325ppm/°C 0.2mΩ/ 0.3mΩ/ 0.4mΩ/ 0.5mΩ: ±175ppm/°C 1mΩ~4mΩ: ±75ppm/°C
	9W		0.2mΩ/ 0.3mΩ/ 0.4mΩ/ 0.5mΩ		0.5mΩ: ±175ppm/°C 1mΩ~4mΩ: ±75ppm/°C
PU5931	3W	-65°C to 275°C	0.5mΩ/ 1mΩ/ 2mΩ/ 3mΩ/ 4mΩ	±1%,±5%	0.2mΩ: ±225ppm/°C 0.3mΩ/ 0.5mΩ: ±175ppm/°C 1mΩ~4mΩ: ±75ppm/°C
	5W		0.2mΩ/ 0.3mΩ/ 0.5mΩ 1mΩ/ 2mΩ/ 3mΩ/ 4mΩ		0.2mΩ: ±225ppm/°C 0.3mΩ/ 0.5mΩ: ±175ppm/°C 1mΩ~4mΩ: ±75ppm/°C
	7W		0.2mΩ/ 0.3mΩ/ 0.5mΩ 1mΩ/ 2mΩ/ 3mΩ/ 4mΩ		0.2mΩ: ±225ppm/°C 0.3mΩ/ 0.5mΩ: ±175ppm/°C 1mΩ~4mΩ: ±75ppm/°C
	10W		0.2mΩ/ 0.3mΩ/ 0.5mΩ		0.3mΩ/ 0.5mΩ: ±175ppm/°C 1mΩ~4mΩ: ±75ppm/°C
	5W		0.3mΩ/ 0.5mΩ/ 1mΩ 2mΩ/ 3mΩ/ 4mΩ		0.3mΩ/ 0.5mΩ: ±175ppm/°C 1mΩ~4mΩ: ±75ppm/°C

Note: Please contact with sales offices, distributors and representatives in your region before ordering.

**FUNCTIONAL DESCRIPTION**

**OPERATING TEMPERATURE RANGE**

High Temperature Range Type:  
-65°C to +275°C (Fig. 4-1)

Normal Temperature Range Type:  
-65°C to +170°C (Fig. 4-2)

**POWER RATING**

Standard rated power at 70°C:

PU3921 = 3W/5W/9W  
PU5931 = 5W/7W/10W

For detail power value, please refer to Table 2.

**RATED VOLTAGE**

The DC or AC (rms) continuous working voltage corresponding to the rated power is determined by the following formula:

$$V = \sqrt{P \times R}$$

Where

V = Continuous rated DC or AC (rms) working voltage (V)

P = Rated power (W)

R = Resistance value ( $\Omega$ )

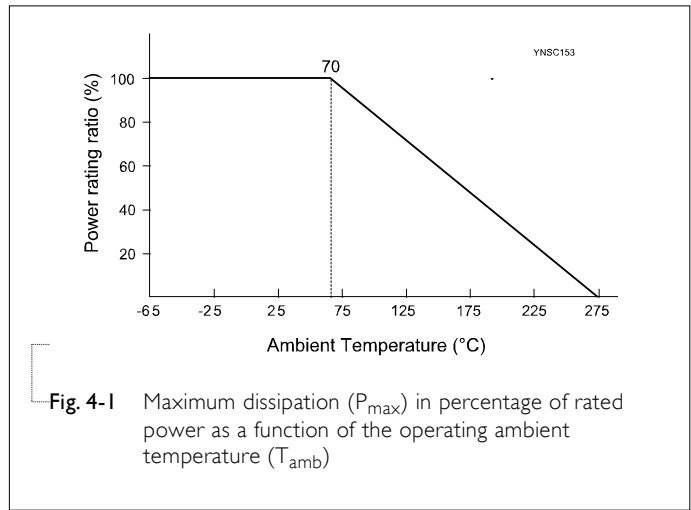

Fig. 4-1 Maximum dissipation ( $P_{max}$ ) in percentage of rated power as a function of the operating ambient temperature ( $T_{amb}$ )

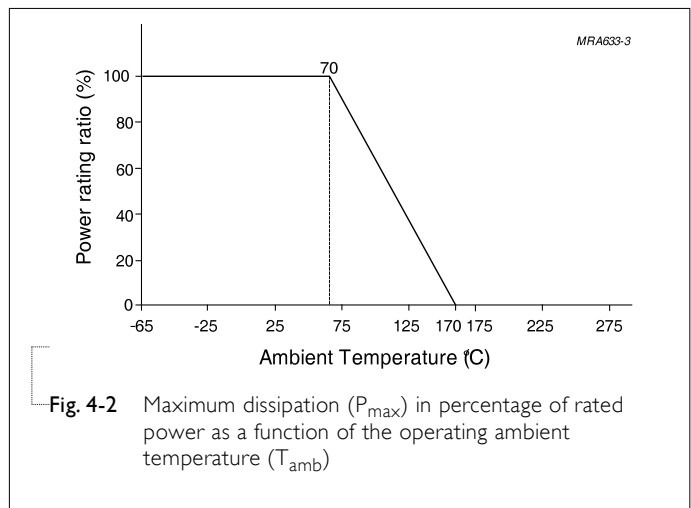

Fig. 4-2 Maximum dissipation ( $P_{max}$ ) in percentage of rated power as a function of the operating ambient temperature ( $T_{amb}$ )

**PACKING STYLE AND PACKAGING QUANTITY**

Table 3 Packing style and packaging quantity

PACKING STYLE	REEL DIMENSION	3921	5931
Embossed taping reel (K)	13" (330 mm)	3,000	1,500

**EMBOSSED TAPE**

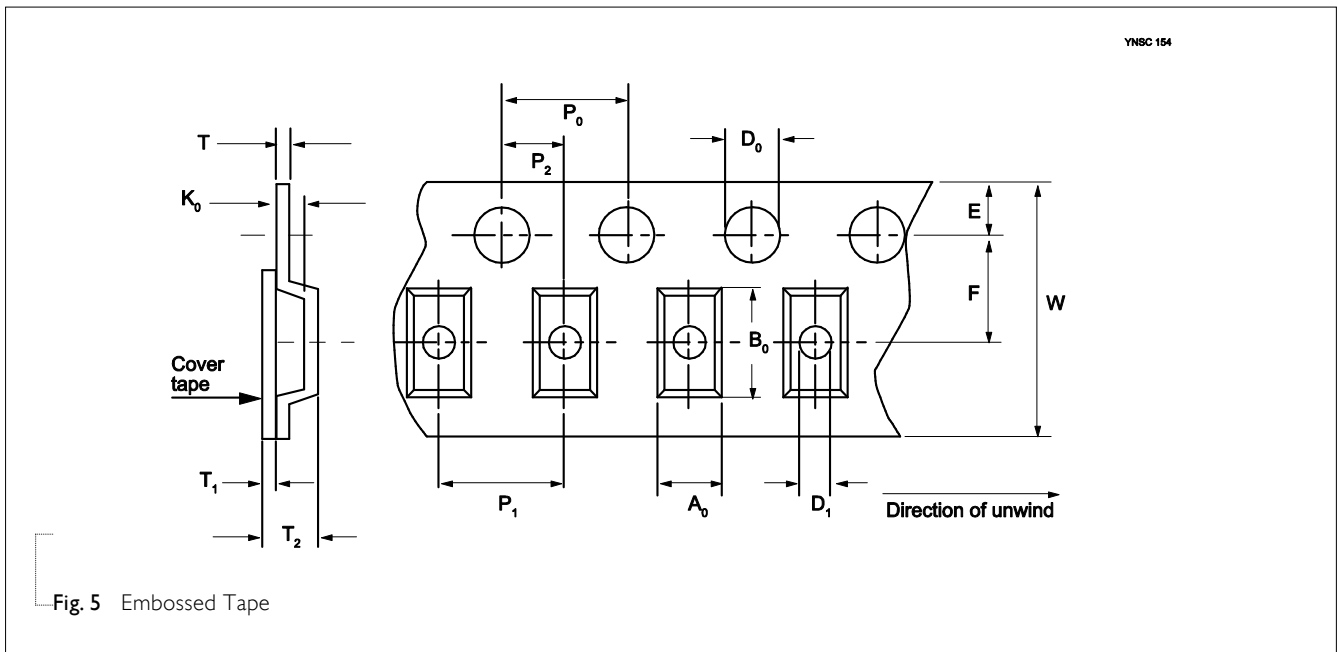

Fig. 5 Embossed Tape

Table 4 Dimensions of embossed tape for relevant chip resistors size

DIMENSION	A <sub>0</sub>	B <sub>0</sub>	D <sub>0</sub>	D <sub>1</sub> MIN.	E	F	K <sub>0</sub> MAX.	P <sub>0</sub>	P <sub>1</sub>	P <sub>2</sub>	T <sub>1</sub> MAX.	T <sub>2</sub> MAX.	T MAX.	W MAX.
PU3921 0.2mΩ/ 0.3mΩ / 0.5mΩ/2mΩ	5.59±0.1	10.41±0.1	1.5±0.1	1.5	1.75±0.1	7.5±0.1	2.13	4±0.1	8±0.1	2±0.1	0.1	2.64	0.41	16.3
PU3921 1mΩ/ 3mΩ/ 4mΩ	5.59±0.1	10.41±0.1	1.5±0.1	1.5	1.75±0.1	7.5±0.1	1.14	4±0.1	8±0.1	2±0.1	0.1	1.65	0.41	16.3
PU5931 ≤0.3mΩ	8.3±0.1	15.62±0.1	1.5±0.1	1.5	1.75±0.1	11.5±0.1	2.39	4±0.1	12±0.1	2±0.1	0.1	2.9	0.41	24.3
PU5931 ≥0.5mΩ	8.3±0.1	15.62±0.1	1.5±0.1	1.5	1.75±0.1	11.5±0.1	1.22	4±0.1	12±0.1	2±0.1	0.1	1.73	0.41	24.3

Unit : mm

**REEL SPECIFICATION**

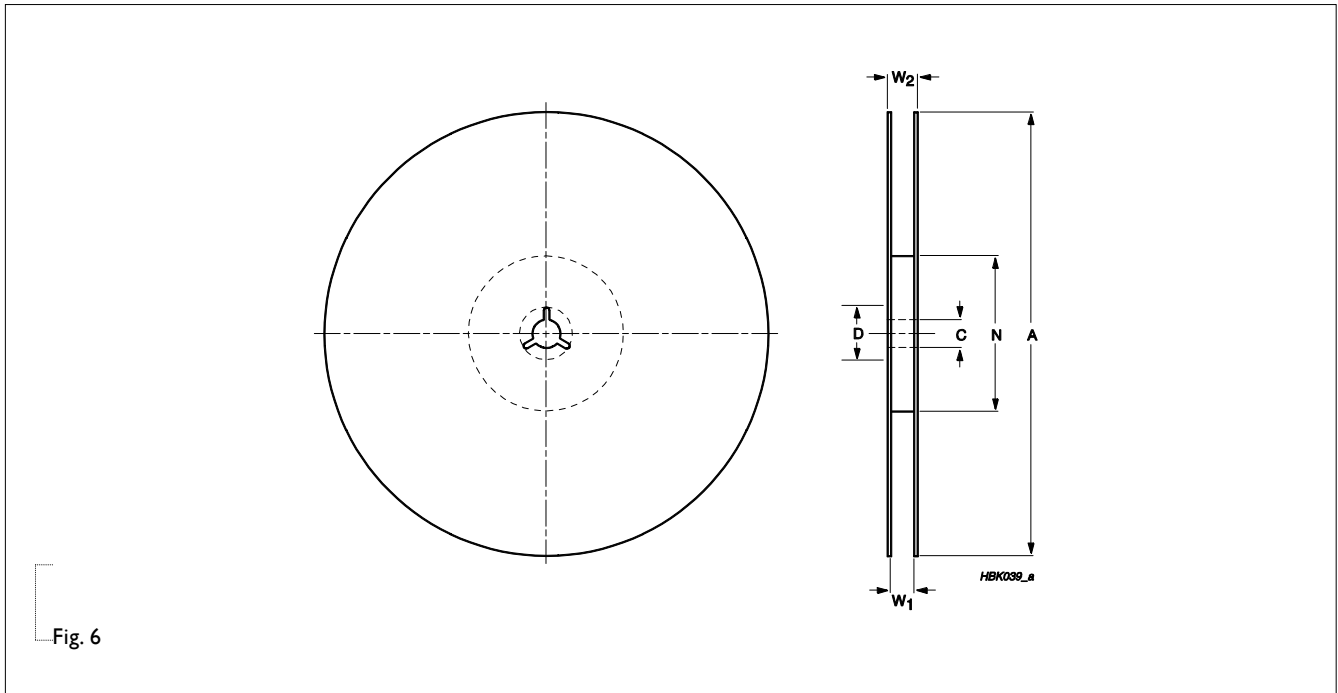

Fig. 6

Table 5 Dimensions of reel specification for relevant chip resistors size; see Fig. 6

PRODUCT SIZE CODE	REEL SIZE	SYMBOL					
		A	N	C	D	W1	W2 max.
3921	13" (Φ 330mm)	330+0 /-3	100±0.5	13.5±0.5	21±0.8	16.4+2.0/-0	22.4
5931	13" (Φ 330mm)	330+0 /-3	100±0.5	13.5±0.5	21±0.8	24.4+2.0/-0	30.4

Unit : mm

**TESTS AND REQUIREMENTS**

Table 6 Test condition, procedure and requirements

TEST	TEST METHOD	PROCEDURE	REQUIREMENTS
Short Time Overload	IEC60115-1 4.13	5 times of rated power for 5 seconds at room temperature	$\pm(1\%+0.0005 \Omega)$ No visible damage
High Temperature Exposure	AEC-Q200 Test 3 MIL-STD-202 method 108A IEC 60115-1 4.25.3	1,000 hours at maximum operating temperature depending on specification, unpowered, Normal Temperature Range Type: $170\pm 3^{\circ}\text{C}$ High Temperature Range Type: $275\pm 5^{\circ}\text{C}$	$\pm(1\%+0.0005 \Omega)$
Moisture Resistance	AEC-Q200 Test 6 MIL-STD-202 method 106F	Each temperature / humidity cycle is defined at 8 hours (method 106F), 3 cycles / 24 hours for 10d with $25^{\circ}\text{C} / 65^{\circ}\text{C}$ 95% R.H, without steps 7a & 7b, unpowered Parts mounted on test-boards, without condensation on parts Measurement at $24\pm 2$ hours after test conclusion	$\pm(1\%+0.0005 \Omega)$
Biased Humidity	AEC-Q200 Test 7 MIL-STD-202 method 103	1,000 hours; $85^{\circ}\text{C} / 85\% \text{RH}$ 10% of operating power Measurement at $24\pm 4$ hours after test conclusion.	$\pm(1\%+0.0005 \Omega)$
Life/ Operational Life/ Endurance	AEC-Q200 Test 8 MIL-STD-202 method 108A IEC 60115-1 4.25.1	1,000 hours at $70\pm 5^{\circ}\text{C}$ applied RCWV 1.5 hours on, 0.5 hour off, still air required	$\pm(1\%+0.0005 \Omega)$
- Resistance to Soldering Heat	AEC-Q200 Test 15 MIL-STD-202 method 210F IEC 60115-1 4.18	Condition B, no pre-heat of samples Lead free solder, $260^{\circ}\text{C}$ , 10 seconds immersion time Procedure 2 for SMD: devices fluxed and cleaned with isopropanol	$\pm(0.5\%+0.0005 \Omega)$ No visible damage
Thermal Shock	AEC-Q200 Test 16 MIL-STD-202 method 107	$-55/+150^{\circ}\text{C}$ Number of cycles is 300. Maximum transfer time is 20 seconds. Dwell time is 15 minutes. Air – Air	$\pm(1\%+0.0005 \Omega)$ No visible damage
Board Flex / Bending	AEC-Q200 Test 21 AEC-Q200-005	Chips mounted on a 90mm glass epoxy resin PCB (FR4) Bending: 2 mm Holding time: minimum 60 seconds	$\pm(1\%+0.0005 \Omega)$

**REVISION HISTORY**

REVISION	DATE	CHANGE NOTIFICATION	DESCRIPTION
Version 1	Jun. 15, 2016	-	- Extend resistor value
Version 0	Mar. 16, 2016	-	- New datasheet for shunt resistor PU series

*“Yageo reserves all the rights for revising the content of this datasheet without further notification, as long as the products itself are unchanged. Any product change will be announced by PCN.”*